

BUILDING SYSTEMS ESSENTIALS

Course 4: Building Control Systems

Half-Day In Class Seminar

BOMA Ottawa, in partnership with Algonquin College, are proud to offer again an education series for building operators and other professionals in Commercial Real Estate.

The Building Systems Essentials is a series of half day “hands-on” seminars aimed to help Building Operators better understand the latest in how buildings function or to provide an overview to Commercial Real Estate professionals to better represent their buildings.

COURSE OUTLINE:

This seminar provides an introductory look at the control systems and devices that can be applied in the operation of commercial properties.

Participants will gain a basic understanding of efficiency and control strategies and how the following can be used to implement such strategies:

- sensors
- controllers and control devices
- control types
- building automation systems
- control system integration
- maintenance procedures
- relevant Acts, Codes, Standards and Regulations
- safety precautions

The course material is developed by BOMA Ottawa together with Algonquin College and will be delivered by an Algonquin College instructor in their state of the art **Down-town Learning Centre**.

Registrants will receive course material and final instructions directly from **Algonquin College**.

Scott Howes is a Engineering Specialist with extensive experience and knowledge in Building Automation Controls and in HVAC technology. Scott has been in the Building Controls Industry for over twenty years in the Ottawa area.

In addition, Scott has been a Professor of part-time studies at Algonquin College since 2010 for the Building Environmental Systems Operator Class II program. Scott has a Bachelor of Science Degree in Industrial Electronics from Sam Houston State University.

Building Control Systems

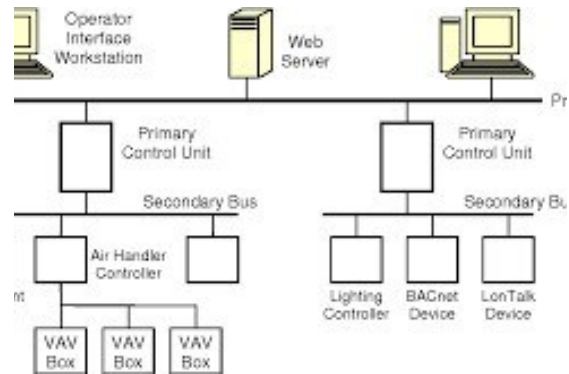

[Register on Line](#)

WHEN: June 20, 2024 8:30 a.m. to 12:00 p.m.

WHERE: Algonquin College Downtown Training Centre
700 Sussex Drive
(corner of Sussex/Rideau across from Rideau Centre)

COST: \$350.00 plus HST (Total \$395.50)

Other Courses in the Series

1. Air Conditioning & Refrigeration
2. Water Treatment & Fire Protection
3. Air Handling Systems
4. Building Control Systems
5. Heating Systems
6. Energy Efficiency for Buildings
7. Building Electrical Systems

Questions? Contact BOMA at
administration@bomaottawa.org

For Office Use Only	
Payment Rec'd	
Cheque #	
Credit Card #	
Expiry	